

**dbx<sup>®</sup> Model 3BX**  
3 band dynamic range enhancer  
*Service* **MANUAL**

*18 Pages*

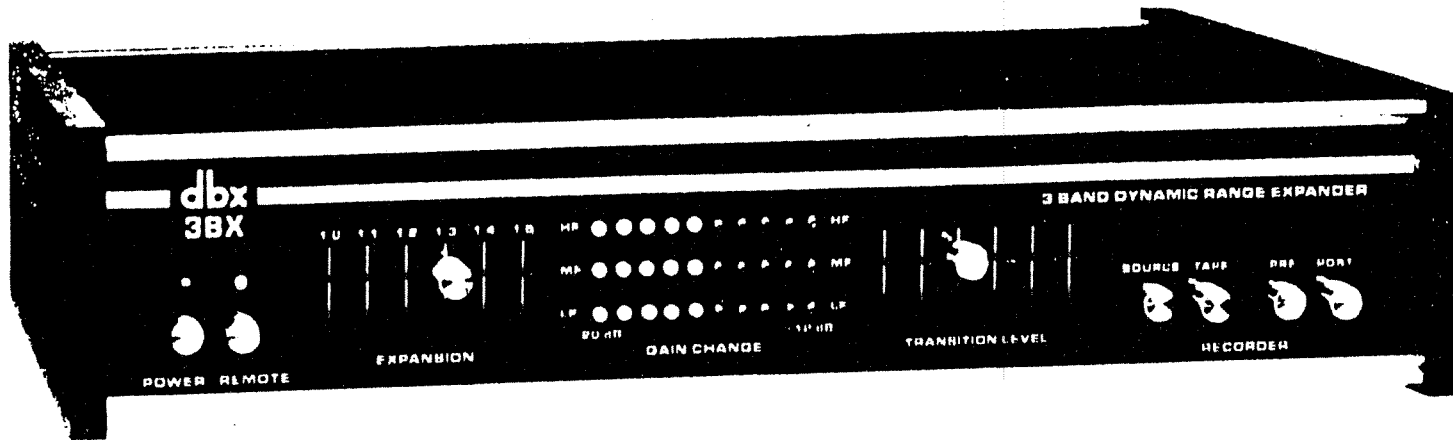

### RMS Detection

The 3BX uses a detection method that acts on the RMS (Root-Mean-Square) value of the input signal. RMS detection is different from either peak or average detection. An RMS detection circuit will not over-react on musical transients or noise spikes, yet it responds precisely and accurately to all changes in input level, and produces natural sounding expansion. In fact, the human ear judges sound levels by their RMS values, which means that the RMS detection circuit in the 3BX electronically parallels the way the human ear hears music. Until recently, however, RMS detection was very complex and costly. dbx has pioneered the development of moderately priced RMS detection circuitry, and has led the industry in applying RMS detection to expanders, compressor/limiters and tape noise reduction systems.

### Linear dB Expansion

Once the signal has been "detected," the expander knows when to increase or decrease its level. The circuit that actually performs this level change is known as a "voltage controlled amplifier" or "VCA." The "AVC" (automatic volume control), and "ALC" (automatic level control) on many cassette recorders are examples of voltage controlled amplifiers, as are the level changing circuits in any modern expander, compressor or limiter. The voltage from the detection circuit increases or decreases the gain of the VCA which increases or decreases the level of the program. While some expanders may increase or decrease the program level by a fixed amount, the 3BX increases or decreases the level of the program on a "linear decibel" basis. This means that the output dynamic range and the input dynamic range are linearly related by the "expansion ratio" over the entire dynamic range (as described earlier) for a smooth, natural sound.

### Attack and Release Times

The expander must decide how fast to react to changes in program level. The length of time between the detection of an input signal level, and its expansion is known as the *ATTACK TIME*. After the expansion of an input signal, the expander allows the input signal to return to its normal level. The amount of time to return to normal is known as *RELEASE TIME*. These terms also apply for compressors and limiters. In general, an expander's detection method, and its attack and release times are not directly related. For example, an expander that uses peak detection may detect an increase in program level very rapidly, yet not act on that increase (by expanding it) until much later. Thus, peak detection does not necessarily imply fast attack time; the expander just cited would have a slow attack time. Conversely, an expander using average detection might have a very fast attack time. While such a unit might not detect an increase in input level until the actual level had begun to decrease again, the expander could react quickly, expanding the program upward at a point where it should be expanded downward. These are extreme examples, but they illustrate the distinction between attack and release times and detection method. Even an expander using an RMS detection scheme may not have optimum attack and release times for every type of musical program. The reason is that the attack and release times of most expanders (and compressor/limiters) are *fixed* (unchanging). In those units where the attack and release times are adjustable via front panel controls, the times are still "fixed" at the control settings—fixed since they do not change as the program requires.

Different types of music require different attack and release times. For example, a smooth classical string quartet number might sound best when expanded with a slow attack and slow release time, where a punchy rock and roll



number might sound best when expanded with a fast attack and release time. Other programs might sound best with a fast attack and slow release time. The point is that attack and release times should be allowed to vary according to the program content for the most natural sound. The 3BX does just that. The 3BX's attack and release times automatically and continuously follow the rate of change of the "envelope" of the program. In fact, because they are not fixed, the 3BX's attack and release times are specified as *rates* which change in response to different program envelopes. The result is a smooth action that does not alter the character of the music as dynamics are expanded and noise is lowered.

### Single vs Multi-Band Expansion

dbx produces three other models of expanders, the 117, 118 and 119, and a combination expander/dbx II tape noise reduction system, the model 128. These expanders are single band units that expand the entire program at all frequencies at the same time. A single band expander is less expensive than a multi-band unit, and this method is satisfactory for most types of program material. In fact, the 117, 118, 119 and 128 outperform every expander marketed except the new 3BX. However, in some cases, when the program has a very heavy bass line, single band expansion can cause audible "breathing" as it also raises high frequency noise when a loud level, low frequency note is detected. Fortunately, the high frequency content of most program material masks this high frequency noise so that the breathing effect is usually unnoticeable. A multi-band expander has the advantage of being able to control the expansion of different frequency bands separately,

eliminating the possibility that a strong note in one band will cause audible effects in another frequency band. After careful consideration, dbx decided that three bands represented the optimum number of frequency divisions for an expander.

### The 3BX

Devices such as "noise gates," "correlators" and "horizontal filters" may be able to subtract noise from certain types of programs, but they do not significantly improve the dynamic range of the program in any other way. In addition, such devices may be misled by certain types of music, causing undesirable changes in the sound, or they may change the frequency response of the program, or even remove parts of the music.

The 3BX represents a new state of the art in expansion. With its three band linear dB expansion, RMS detection, and program-controlled attack and release rates, it avoids the midrange coloration of pre-emphasized units (so called "weighted" expanders), the "breathing" of single band units, and the "noise modulation" of units that divide the spectrum into many bands. The 3BX does not subtract any frequency components from the music. Instead, it reduces its gain during quiet passages and increases its gain during loud passages, achieving 35dB or more of natural sounding expansion.

*\*The envelope is a graph of the program level versus time; see the Glossary for a further definition.*

INITIAL FACTORY TEST & ALIGNMENT PROCEDURE

DBX MODEL 3BX

VERSION I

TEST EQUIPMENT REQUIRED

VERSION I WITH SEPARATE  
VCA/RNS PLUG-IN MODULES  
XFM RMTD ON P.C. BOARD,  
(APPROX S/N 14, 100 & BELOW)

<u>QUANTITY</u>	<u>ITEM</u>	<u>TYPE OR EQUIVALENT</u>
1	Signal Oscillator	Kron-Hite 4200, Heath 1G1272
1	Digital Multimeter	Dana 3300, Simpson 464 Heath 1M2202
1	Oscilloscope	Any (Covering Audio Range)
1	Wide Range DB Meter	DBX SK-C-1026, HP427 Heath 1M5238
1	Harmonic Distortion Meter	DBX SK-B-1070, Heath 1M58 HP 330, GR1500, 1900
1	± 3 Db Meter (REF 1 VRMS)	DBX SK-C-1071
1	Remote Simulator	DBX RS-1
1	Tone Burst Generator	GR 1396B
1	GR Double Banana to 2 Phono Plug, Shielded Cable	
1	GR Double Banana to 1 Phono Plug, Shielded Cable	

Note: All Input/Output levels referenced to 0 DbV = 1.000 VRMS AC.

Test Set-Up

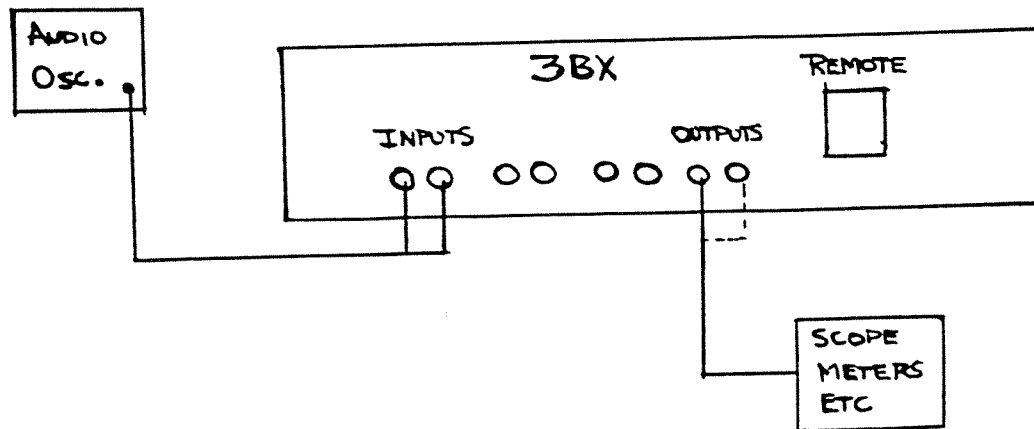

3BX SEQUENCE OF STEPS

- 1) Power Supply & DC Tests
- 2) RMS Adjustments
- 3) VCA Level Adjustments
- 4) VCA Distortion
- 5) Tracking
- 6) Noise
- 7) Transition Level Range
- 8) Relative Level Set
- 9) Relative Level Response
- 10) Frequency Response
- 11) Remote Simulator
- 12) Maximum Output Level
- 13) LED Display
- 14) Output Clamp
- 15) Tone Burst Response
- 16) Wrap-up

## 1) Power Supply & DC Tests

- 1.1) Plug 3BX to be tested into appropriate power (120 or 240 VAC) and ensure that the power and remote LED light in the correct sequence.
- 1.2) Connect a DVM from the plus side of C51 to ground and adjust R135 for + 12.00 vdc.
- 1.3) Connect to the minus side of C58. A reading of between -11.88 to -12.120 should be noted. \*
- 1.4) Connect the DVM directly across R145 and short circuit the plus supply to ground. Voltage reading should not exceed .450 vdc.
- 1.5) Remove the short from the plus supply and connect to the minus supply. With the DVM directly across R138, this reading should also not exceed .450 vdc.
- 1.6) Remove the short and check for resumption of normal operating voltages. (Given in steps 1.2 & 1.3) Install jumpers Y1 & Y2 and check for normal operation.
- 1.7) Operate the remote switch in and out of mode, while checking that the gates of  $\phi_1$  through  $\phi_4$  change polarity. (Typically from +.4 to -6 vdc)
- 1.8) Install RMS & VCA in their respective connectors (215) (210). RMS in J7, 8, 9. VCA in J1, -6.

## 2) RMS Adjustments

- 2.1) With the "remote" switch out, the "source" switch pushed "in" and both the expansion and transition controls fully to the left of their travel, feed 100 Hz at -15 dBv (.178 VAC) to the 3BX inputs 1 & 2 (which are marked from pre-amp output.)

### 2.2) Low Band Adjust:

Connect the scope to pin "7" of OA12 (Anode CR2) and adjust the symmetry control located on the RMS module 215 (nearest the rear panel) for a symmetrical waveform. (equal peaks).

- \* Note: For tests 1.4, 1.5 and 1.6 jumpers Y1 & Y2 should not be in board.

- 2.3) Connect the DVM to pin "1" of OA12 and adjust R58 for a reading of 0 volts to  $\pm .01\text{VDC}$ .
- 2.4) Mid Band Adjust:  
Connect the scope probe to pin "1" of OA10 (Anode CR4) with an input of -10 dBv (.316 VAC) at 1 khz and adjust the center RMS module for a symmetrical waveform.
- 2.5) Connect the DVM to pin "1" of OA11 and adjust R76 for 0 vdc  $\pm .01$  vdc.
- 2.6) High Band Adjust:  
Connect the scope probe to pin "1" of OA9 (Anode CR8) leaving the input set for -10 dBv at 1 khz and adjust the remaining RMS module for a symmetrical waveform.
- 2.7) With an input of -27dBv (.045 VAC) at 10 khz, connect the DVM to pin "1" of OA8 and adjust R98 for 0 VDC  $\pm .01$  VDC.

### 3) VCA Level Adjustments

- 3.1) Set the input to 0 dBv (1 VAC) at 100 hz, and while observing channel 1 output, adjust R69 for unity gain. (input = output)
- 3.2) Switch the oscillator to 1 khz, and adjust R90 for unity gain.
- 3.3) Switch the oscillator to 10 khz, and adjust R109 for unity gain.
- 3.4) Repeat the last three steps, readjusting if necessary.
- 3.5) Switch the oscillator back to 100 hz, and while observing Channel 2 output, adjust R70 for unity gain.
- 3.6) Switch to 1 khz, and adjust R91 for unity gain.
- 3.7) Switch to 10 khz, and adjust R110 for unity gain.

### VCA Distortion

- 4.1) Reset the oscillator to 0 dBv at 100 hz and adjust the low band VCA (J 4) symmetry control (the trimpot protruding from VCA PC Board) for minimum second harmonic distortion. (Must be below .03 %)

- 4.2) Set the oscillator to 1 khz and adjust the Mid band VCA (J5) for minimum distortion.
- 4.3) Set the oscillator to 10 khz and adjust the high band (VCA) (J6) for minimum second harmonic distortion.
- 4.4) Repeat steps 4.1 through 4.3 for Channel 1 adjusting J1, J2 and J3 respectively.
- 4.5) Check that the distortion readings agree with chart below.

FREQ.	HARMONIC	1.0 EXP.	1.5 EXP.
100 HZ	2 <sup>nd</sup>	<.03%	<.1%
	3 <sup>rd</sup>	<.03%	<.1%
1 KHZ	2 <sup>nd</sup>	<.03%	<.1%
	3 <sup>rd</sup>	<.03%	<.1%
10 KHZ	2 <sup>nd</sup>	<.03%	<.1%
	3 <sup>rd</sup>	<.03%	<.1%

#### 5) Tracking

- 5.1) With the remote switch disengaged and expansion control set to 1.5, adjust the transition control for a level match with an input of -10 dBv at 100 hz.
- 5.2) Change the input level in 10 dB increments from + 10 to -40 dB. The output should change 15 dB for every 10 dB input change.
- 5.3) Repeat at 1 khz and 10 khz. (Re-set level match for each band.) (Note: At 10KHZ it is only necessary to step from +10 to -30DB)

#### 6) Noise

- 6.1) Set the expansion control to 1.0, and short both inputs. Output reading for both channels should be -85 dBv or better.

#### 7) Transition Level Range

- 7.1) Set the input to -10 dBv at 1 khz with the expansion control at 1.5.
- 7.2) Sweep the transition level control through it's complete travel, ensuring that a 20 dB output range is obtained.

### 7.3) LED DISPLAY BOARD CALIBRATION

Short the input to the 3B $\bar{X}$ . (Note: The input can be shorted by placing all the DB step switches on the Kron-Hite 4200 Oscillator to their "out" positions.)

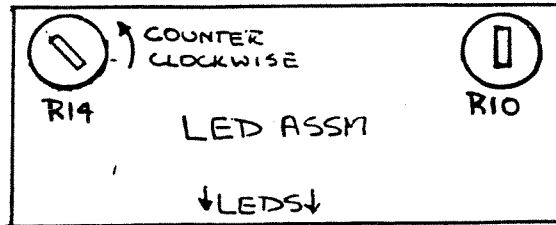

Place expansion control fully to the left (1.0) Rotate R14 fully CCW.

Rotate R10 CCW until red led lights; note position of R10 wiper.

Rotate R10 CCW until yellow led lights; note position of R10 wiper.

Position R10 wiper equally between previously noted position wax R10 and R14.

(Note: On some led boards it may be necessary to rotate R14 slightly CW to get the yellow led to light)

RED LED BEGINS



TO LIGHT

SET POT.

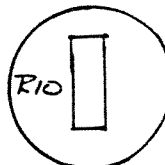

MID-WAY  
BETWEEN.

YELLOW LED BEGINS



TO LIGHT



### 8) Relative Level Set

- 8.1) With an input level of -15 dBv at 100 Hz and expansion control at 1.5, adjust the transition level control so that a level match is obtained. At this point, the control should be at approximately mid-travel.
- 8.2) Repeat for -10 dBv at 1 khz and -27 dBv at 10 khz.

### 9) Relative Level Response

- 9.1) Set expansion to 1.5 with input to -10 dBv at 1 khz, and adjust transition control for level match.
- 9.2) Check the output at 100 Hz and 10 khz and compare level readings with those provided in the Level Response Chart. Readings should fall within  $\pm 1$  dB of specified levels.
- 9.3) Repeat with a -30 dB level match. Check both channels.

INPUT AT — KHZ	OUTPUT AT 100HZ	OUTPUT AT 10 KHZ
-10 dbv at 1 KHZ	-8.5 dbv	-2.0 dbv
-30 dbv at 1 KHZ	-28.3 dbv	-21.5 dbv

### 10) Frequency Response

- 10.1) With an input of 0 dBv at 1 khz, set the expansion control to 1.0, and sweep the oscillator from 20 Hz to 20 khz. The output should remain flat to within  $\pm \frac{1}{2}$  dB.

### 11) Remote Simulator

- 11.1) Plug the simulator into the Cinch Jones connector located on the rear panel. Place the remote switch on the front panel to remote.
- 11.2) Check operation of the bypass switch (S3) Phase should shift 180°. Return to "remote" and output should increase + 5 dB.
- 11.3) With S2 in the 1.5 position and an input of -10 dBv at 100 Hz, S1 should shift the output level to -5 dBv in one position and -15 dBv in the other.
- 11.4) In the 1.0 position S2 should return the output signal to -10 dBv.
- 11.5) Repeat steps 11.3 and 11.4 at 1 khz and 10 khz.
- 11.6) Repeat for Channel 2.

## 12) Maximum Output Level

- 12.1) With the remote switch on 3BX in the "out" position, set the oscillator to 1 khz @ + 10dB and increase the output level of the test unit (full expansion) by adjusting the transition level control until clipping of the waveform is observed on the oscilloscope. A "7 volt RMS" (20V P-P) output should be achieved before clipping occurs, and the waveform should clip symmetrically.

## 13) L.E.D. Display

- 13.1) With an input of + 10 dBv at 1 khz and expansion control at 1.5, move the transition control from left to right and ensure that the leds turn on in sequence. With transition level fully to the right, all the red leds should be lit. At no time should two leds turn on at the same time, nor should a red and yellow led be lit simultaneously. (Some yellow leds should be lit in both the high and low band and occasionally in the midband with the threshold control fully to the left.)
- 13.2) With the transition control fully to the left and both inputs shorted, move the expansion control from 1.0 to 1.5 and observe that the yellow leds turn on in sequence. As the expansion control is moved to the right, all three bands should have their yellow leds light approximately at the same time. With the expansion control fully to the right and the transition control fully to the right, all the yellow leds should be lit. Check to make sure they are all the same color. With a shorted input and both the transition and expansion controls fully to the left, no leds should be lit. Adjust if necessary.

## 14) Output Clamp

- 14.1) When the power switch is activated, a brief pause should be observed on the oscilloscope, before the output climbs to it's correct level.

## 15) Tone Burst Response

- 15.1) With a tone burst input of 8 cycles on, 128 off and the expansion control set to 1.5, check that the output as observed on the oscilloscope resembles the drawings provided for 200 Hz, 700 Hz, 3 khz and 7 khz for both channels. Transition control may be adjusted to get the correct wave shape.

16) Wrap Up

- 16.1) Install tie wraps on all modules.
- 16.2) Wax all trim pots.
- 16.3) Fill out route tag and place in Burn-in rack with the appropriate power applied (120 or 240 VAC) for three days.

SEQUENCE OF STEPS FOR FINAL TEST

- 1) Check Power and Remote LED'S and LED Display
- 2) VCA Level and Distortion
- 3) Relative Level Set
- 4) Relative Level Response
- 5) Tone Burst
- 6) Noise
- 7) Clamp
- 8) LED Display
- 9) Clipping

3BX TONE BURST : 80N/128 OFF 15:1 EXT

200Hz

700Hz

3KHz

7KHz

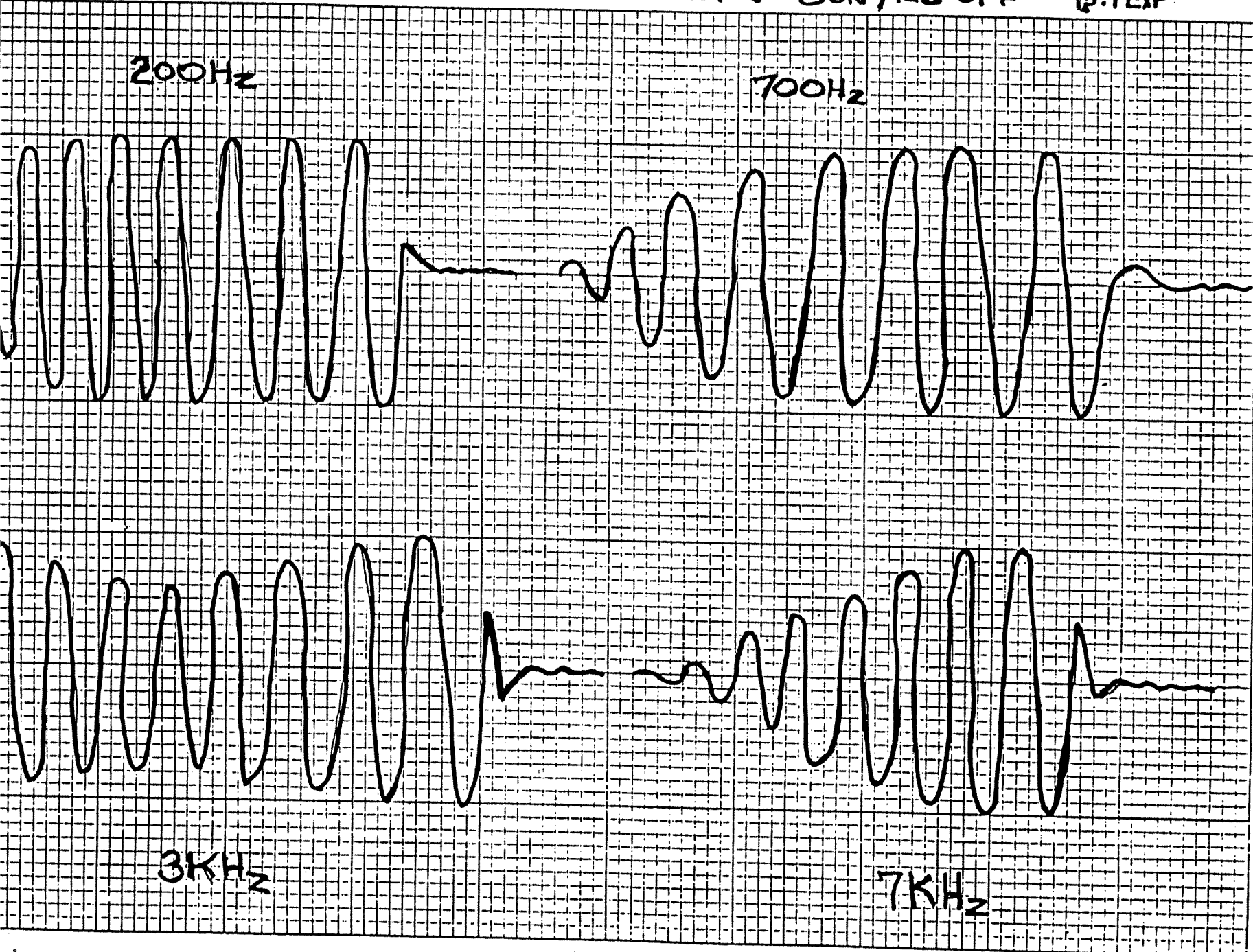

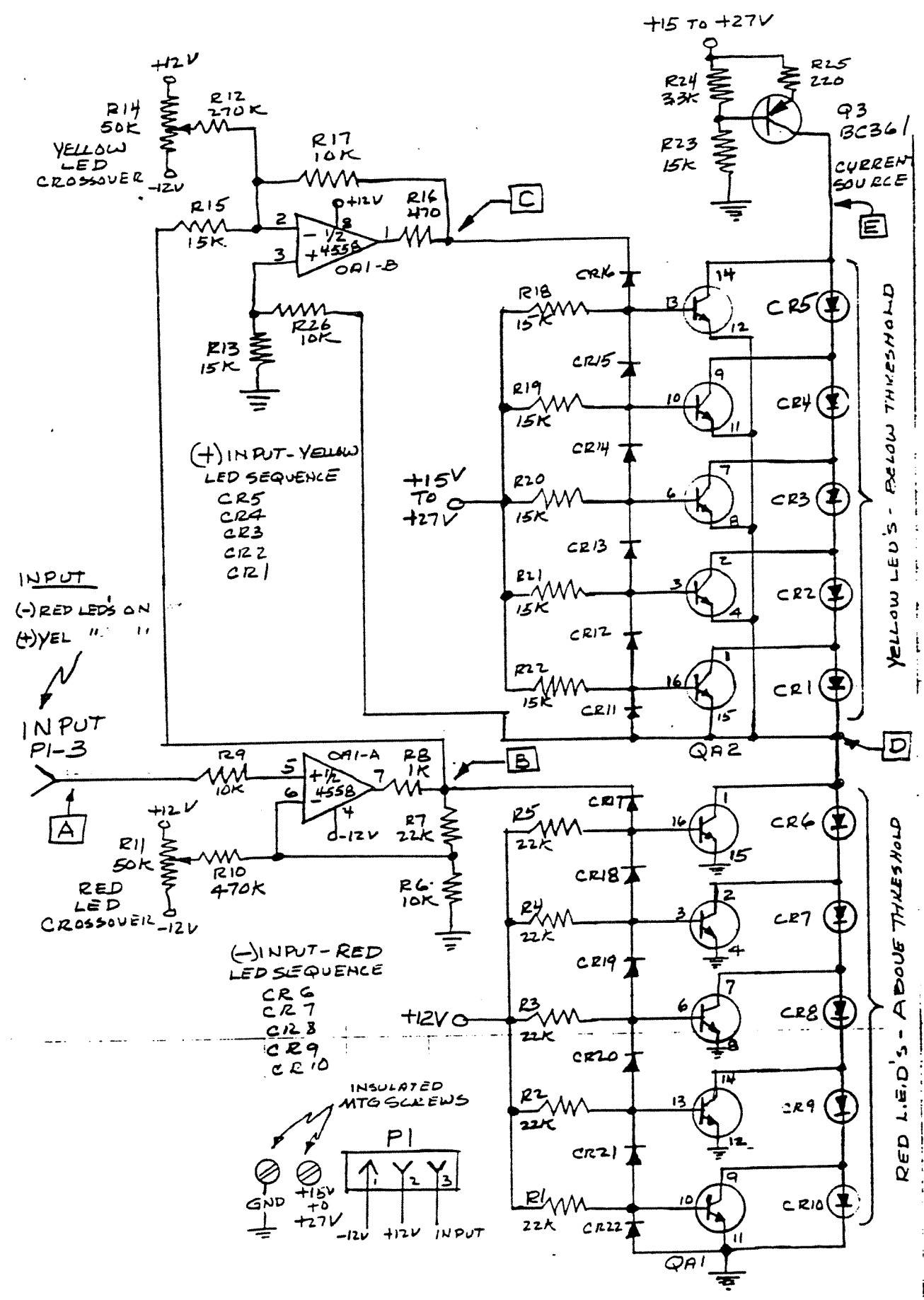

REV 2  
 SIMPLIFIED SCHEMATIC - LED DISPLAY - FOR MOD 3BX

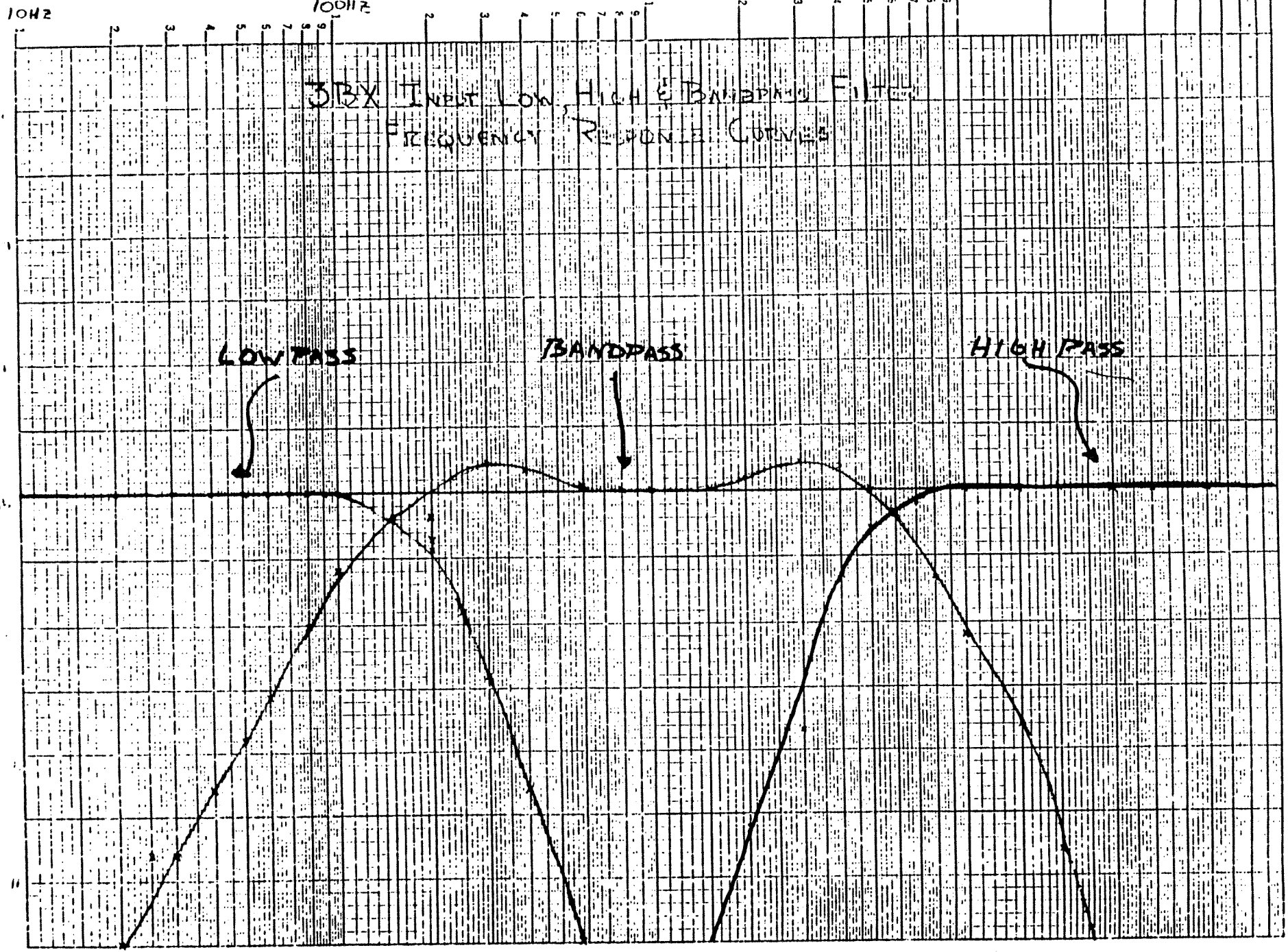

3 BX INPUT LOW, HIGH & BANDPASS FILTERS  
FREQUENCY RESPONSE CURVES

LOW PASS

BANDPASS

HIGH PASS

TAPE RECORDER

PREAMP OR RECEIVER

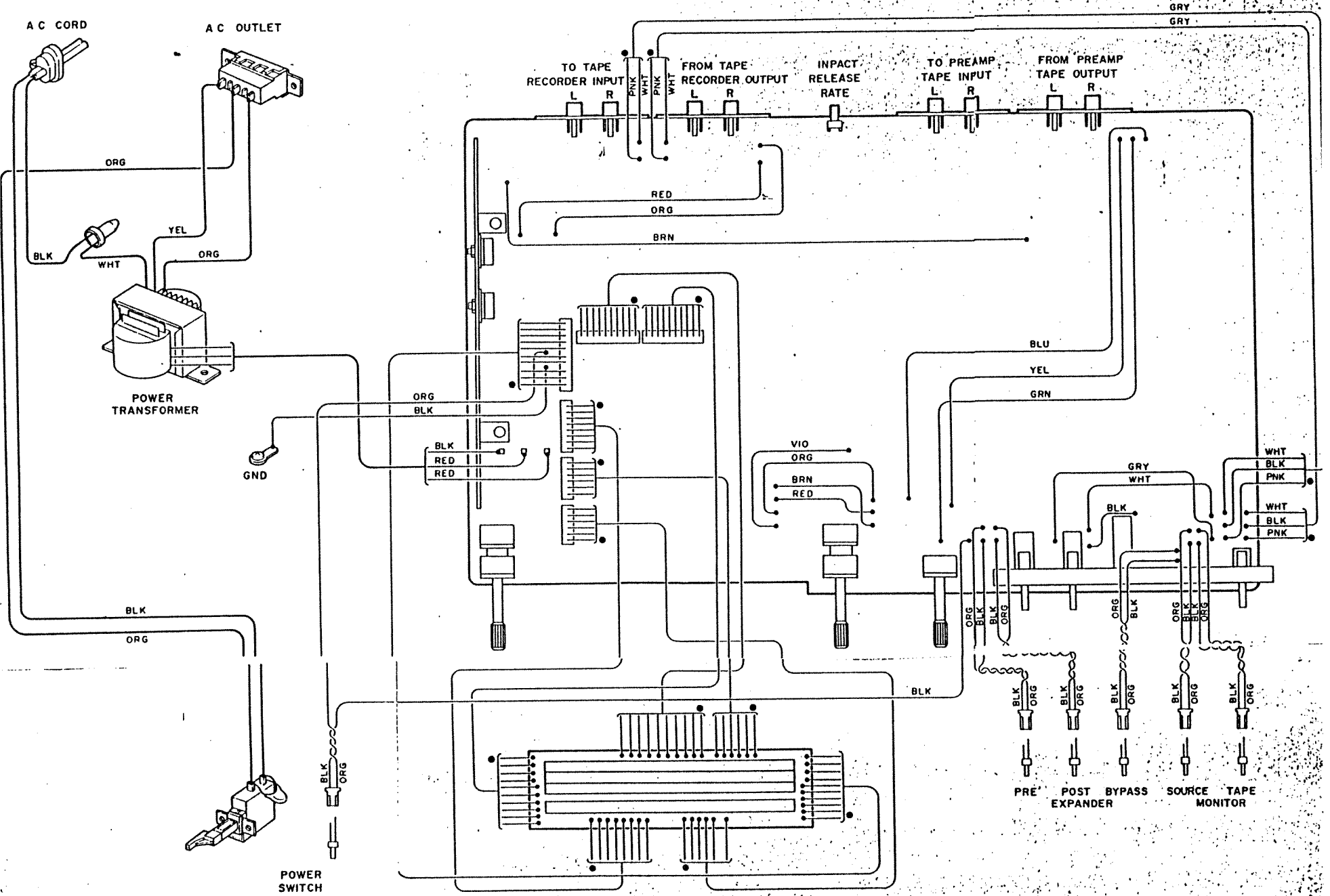



# SCHEMATIC

20

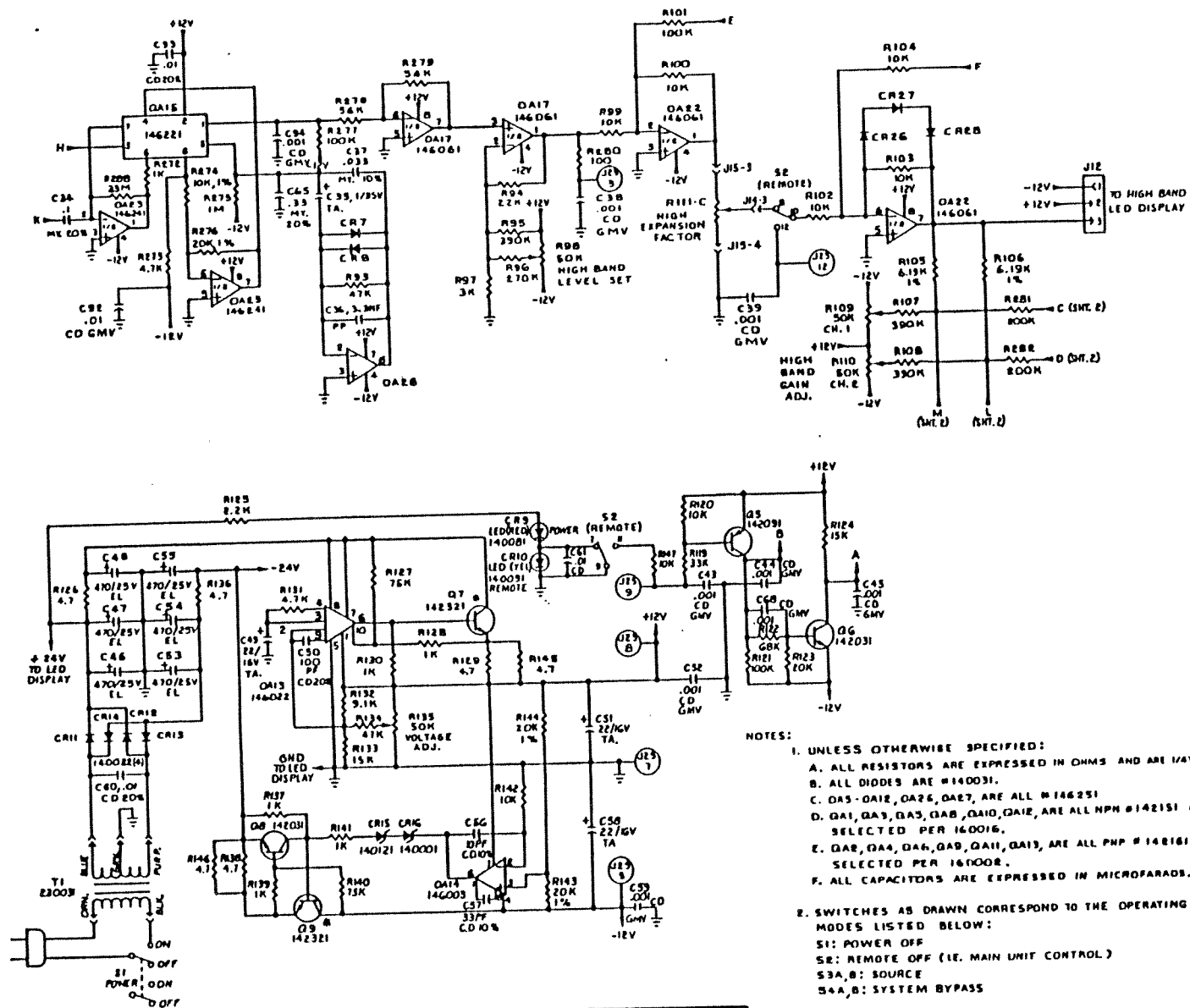

Manufactured under one or more of the following U.S. patents: 3,681,618; 3,714,462; 3,789,143; 4,101,849; 4,097,767. Other patents pending.

# SCHEMATIC

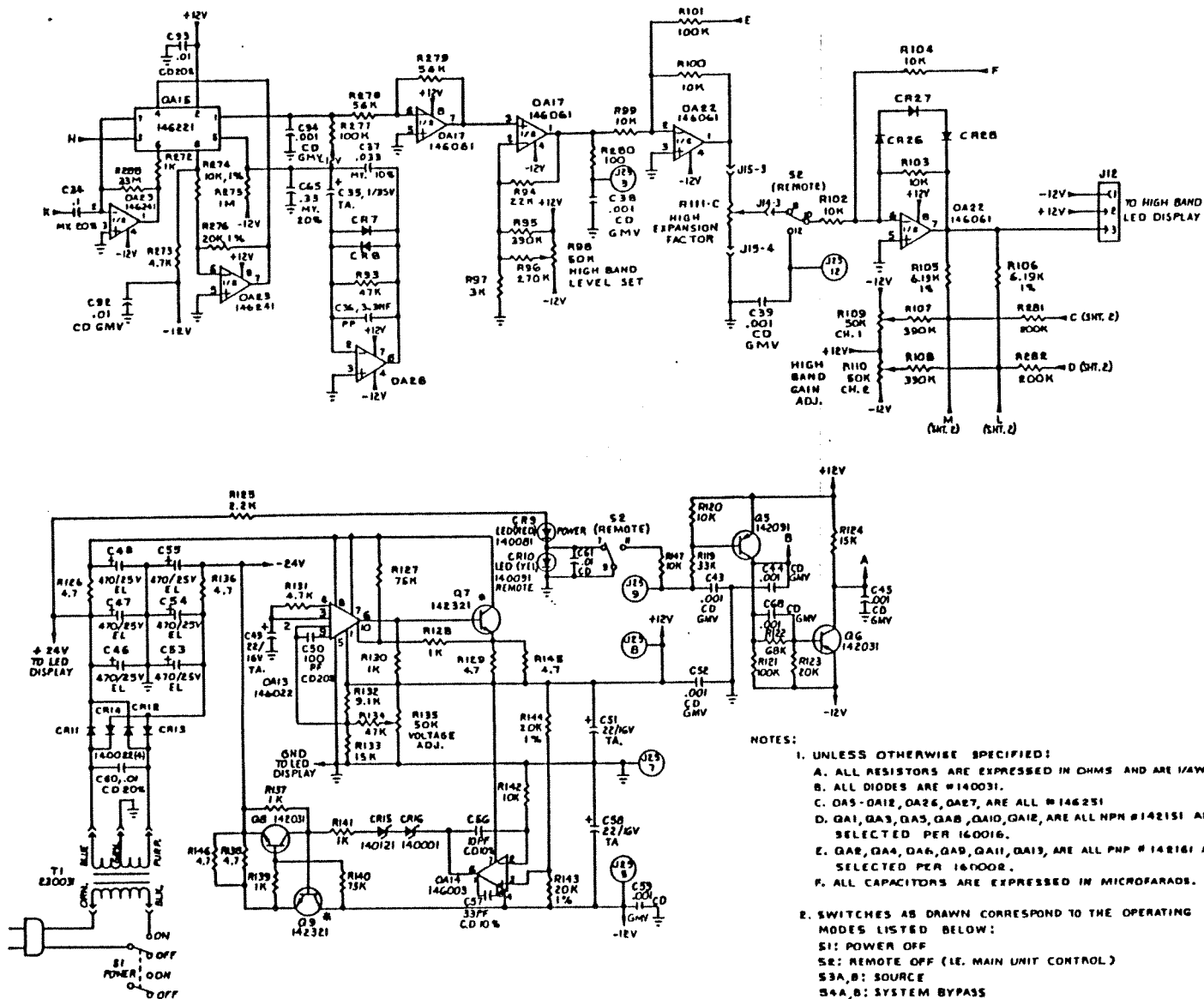

Manufactured under one or more of the following U.S. patents: 3,681,618; 3,714,462; 3,789,143; 4,101,849; 4,097,767. Other patents pending.

